

Imatest Motorized Gimbal

Converting between Stray Light and Standard Configurations



The contents of this document are confidential and proprietary to Imatest. This document is only intended for use by Imatest authorized persons. Unauthorized use, reproduction, and disclosure of any part of this document is prohibited.

Imatest trademarks or logos appearing herein are trademarks of Imatest, LLC.

Safety

The Imatest Motorized Gimbal shall only be operated as described in this manual. Deviating from this manual and altering or not following the methods and instructions in this manual to attain the desired data may result in personal injury or death or damage to the machine. The machine is a tool and there is no guarantee that the data will be error free. Imatest LLC is not responsible for any personal injury or death or damage to the machine.

While the machine has been optimized for use with Imatest equipment, charts, and software, it is the operator's responsibility to confirm that no collision between components, cabling, or surroundings occurs. Such collisions may damage components on the machine or alter the results and make them inaccurate.

WARNINGS:

- Do not place hands, fingers, or any parts of the body between the gimbal components or any other components while the machine is in operation.
- Machine should be placed on a level surface.

Zaber Rotary Stage disclaimer

Zaber's devices are not intended for use in any critical medical, aviation, or military applications or situations where a product's use or failure could cause personal injury, death, or damage to property. Zaber and Imatest LLC disclaim any and all liability for injury or other damages resulting from the use of these products.

Zaber Rotary Stage precautions



Pinch Hazard: Keep hands and all body parts away from the moving carriage. Use caution when mounting components near the path of the carriage; they may create unexpected pinch hazards.



Backdriving: If motor power is suddenly lost, any vertical loads may fall quickly or high inertial loads may fail to stop. This may cause personal injury or damage to the payload, the device, or to electronics. This device is not recommended for loads greater than 2.5kg.



Important: Mounting large objects onto the gimbal or using this component in a multi-axis system may create new or unexpected risks. Always perform a risk analysis for your complete system in its operating environment.

Initial Setup

Stray Light Configuration Wireframe

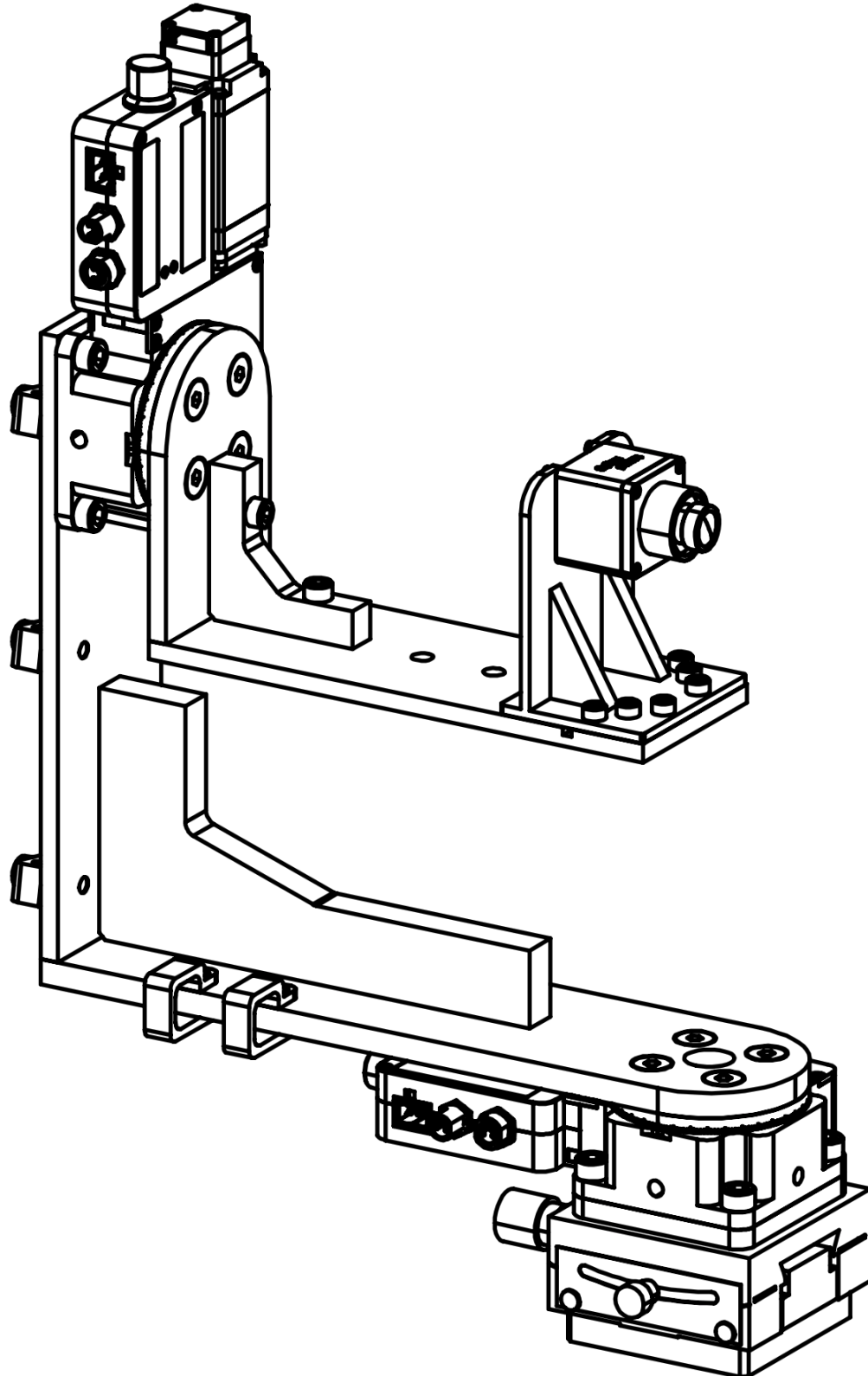

Initial Setup

Standard Configuration Wireframe

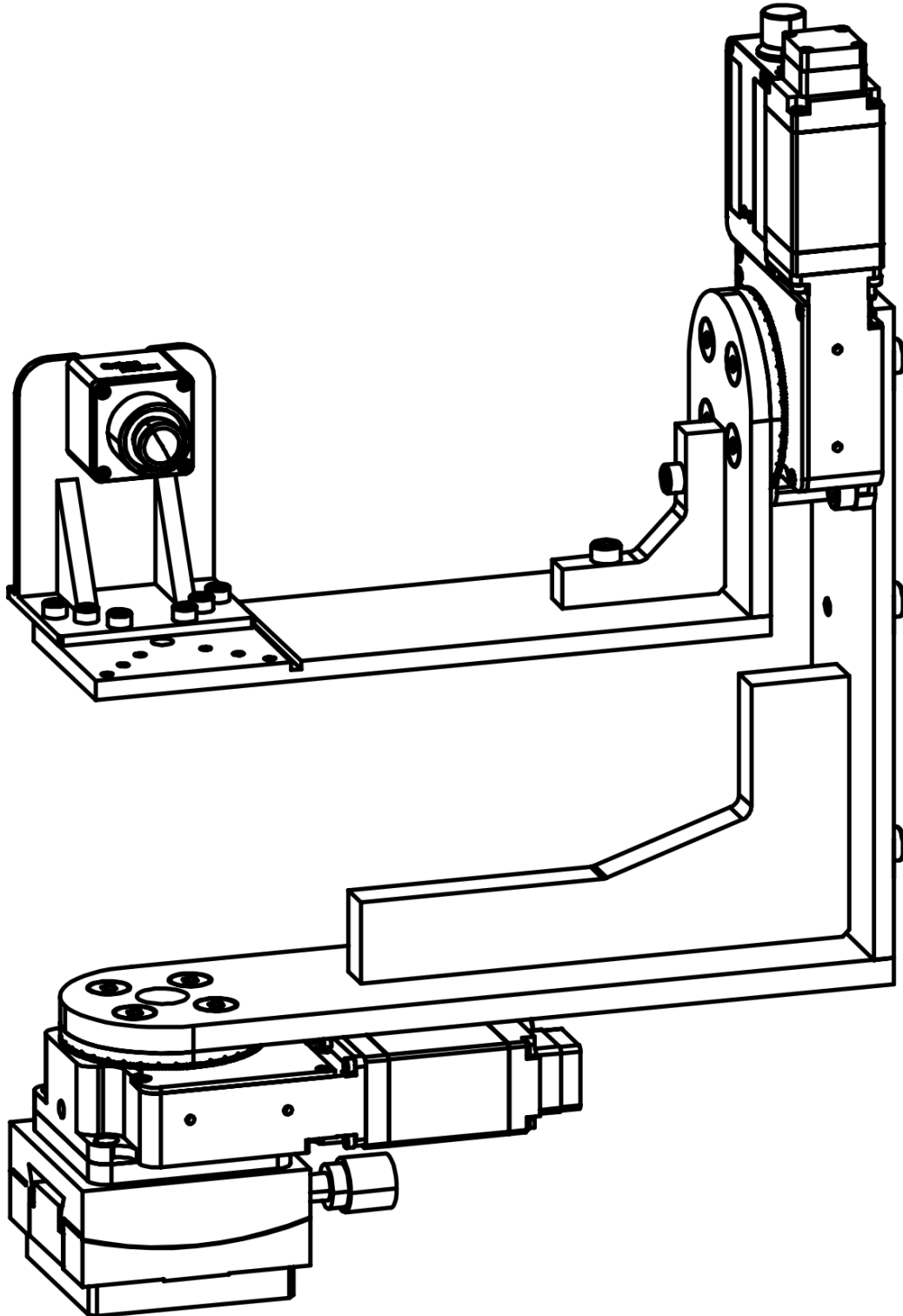

Assembly Instructions - Stray Light Configuration

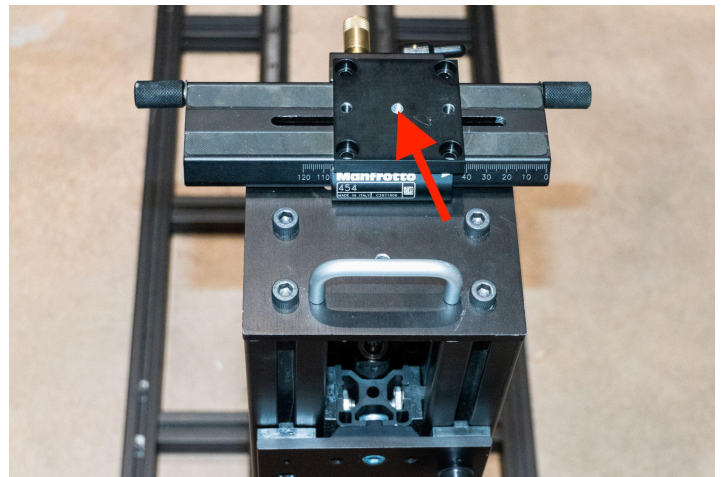
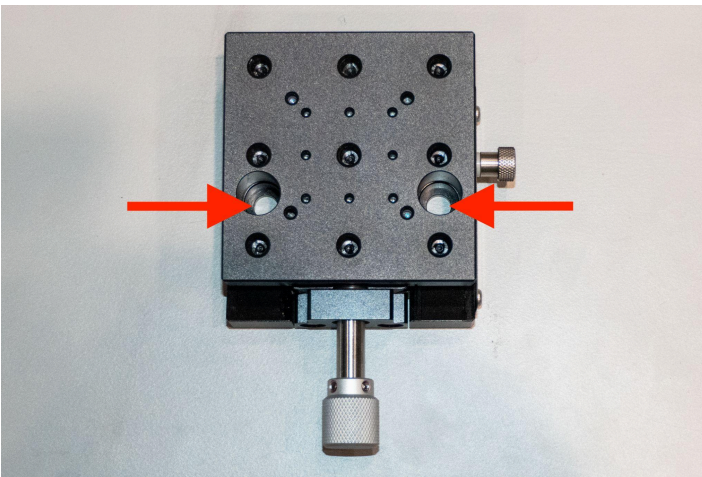

1. Adjust the Goniometer so that the counterbore holes are accessible, as shown in the image above.
2. **The goniometer may be mounted to metric optical breadboards. If using the Motorized Gimbal with a breadboard, skip Step 3 & 4.**
3. If using the Motorized Gimbal with a tripod or manual x-axis modular test stand:
 - a. Mount the adapter plate (Part GC) to the tripod or Manfrotto slider using the 1/4"-20 threaded hole. Tighten using a coin or large flathead screwdriver. **Ensure to match the orientation shown above.**

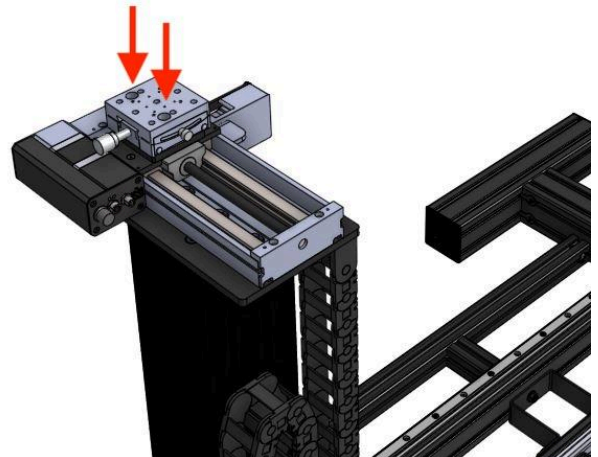
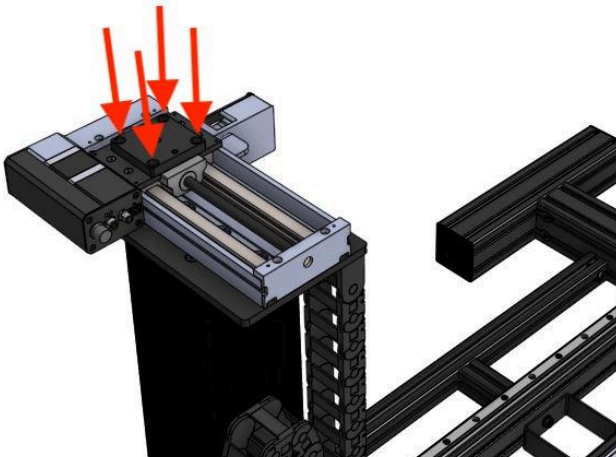

4. If using the Motorized Gimbal with the motorized x-axis Modular Test Stand:
 - a. Mount the adapter plate (Part GC) to the x-axis stage using four M6 x 12mm screws. Tighten with a 5mm hex key **Ensure to match the orientation shown above.**
5. Mount the Goniometer (Part GB) to the Adapter Plate (Part GC) using two M6 x 12mm screws, as shown above. Tighten with a 5mm hex key. **Ensure to match the orientation shown above.**

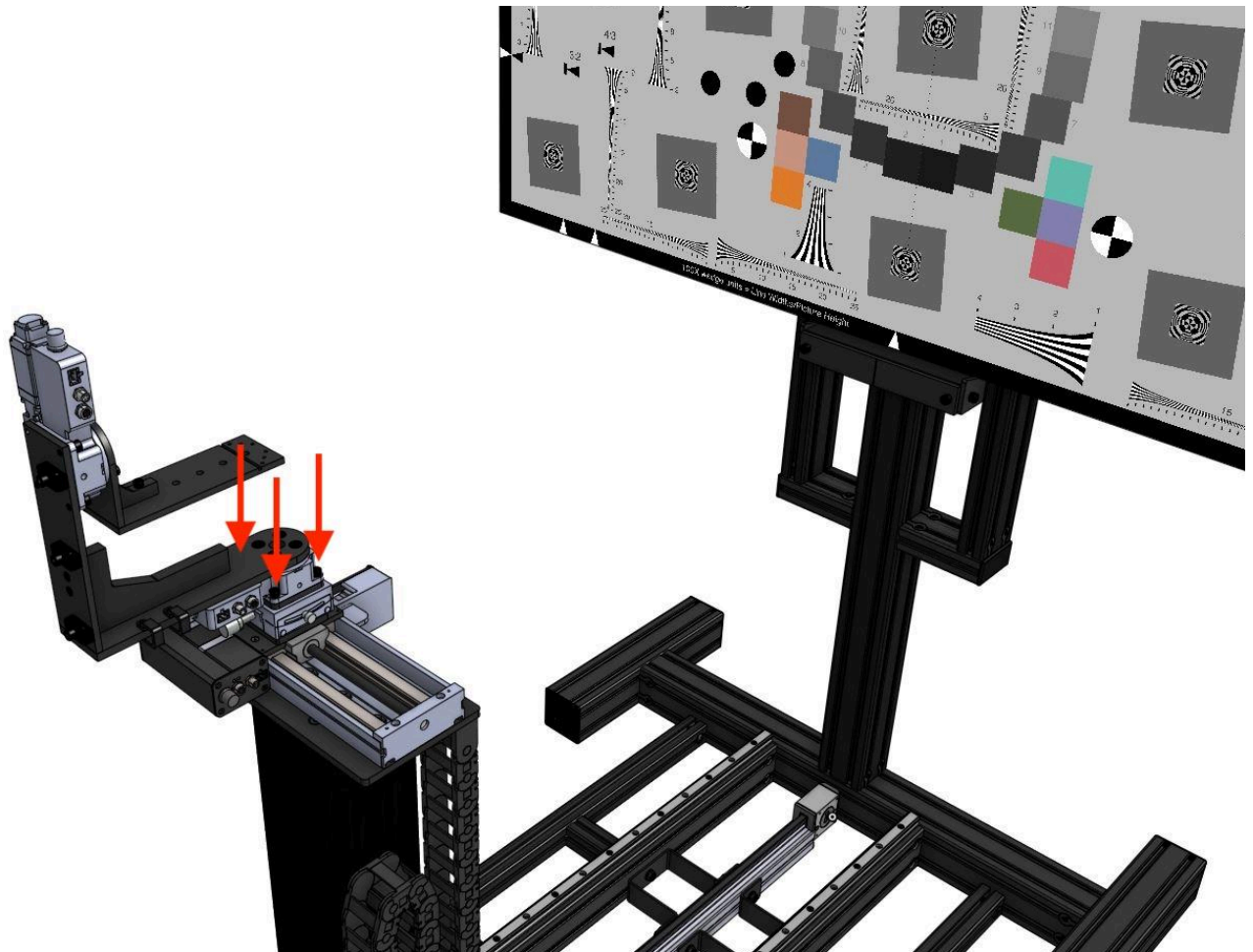

6. Mount the Motorized Gimbal (Part GA) to the Goniometer (Part GB) using three M6 x 16mm screws (Part GE), as shown in the image above. Tighten with a 5mm hex key. **Ensure to match the orientation shown above.**

Assembly Instructions - Converting to the Standard Configuration

7. Unmount the Motorized Gimbal by removing three M6 x 16mm screws from Step 6
8. Unmount the Goniometer by removing the two M6 x 12mm screws from Step 5
9. Unmount the Adapter Plate (Part GC) by removing the four M6 x 12mm screws from Step 4 (or Step 3)
10. Continue to the Standard Configuration Instructions (Page 7)

NOTE: These instructions are also applicable for the Adjustable Motorized Gimbal

Assembly Instructions - Standard Configuration

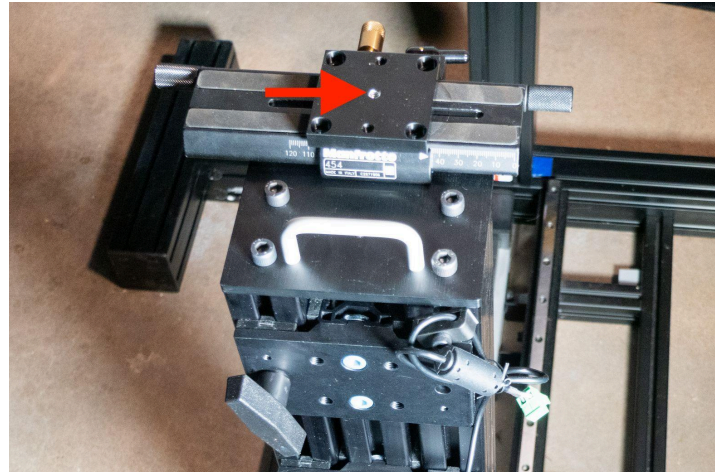
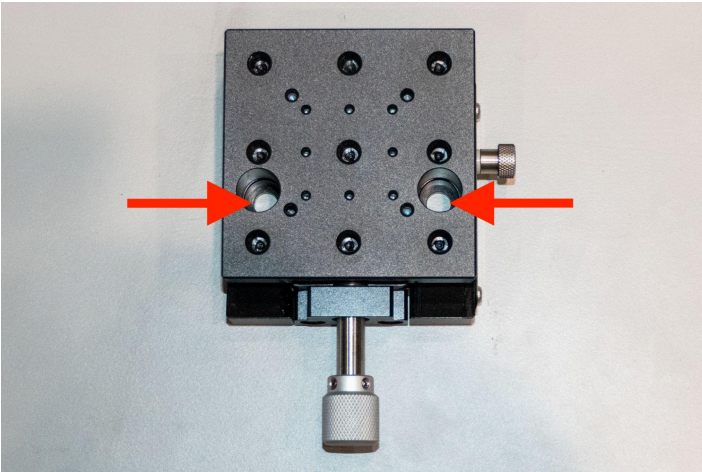

11. Adjust the Goniometer so that the counterbore holes are accessible, as shown in the image above.
12. **The goniometer may be mounted to metric optical breadboards. If using the Motorized Gimbal with a breadboard, skip Step 13 & 14.**

13. If using the Motorized Gimbal with a tripod or manual x-axis modular test stand:
 - a. Mount the adapter plate (Part GC) to the tripod or Manfrotto slider using the 1/4"-20 threaded hole. Tighten using a coin or large flathead screwdriver. **Ensure to match the orientation shown above.**

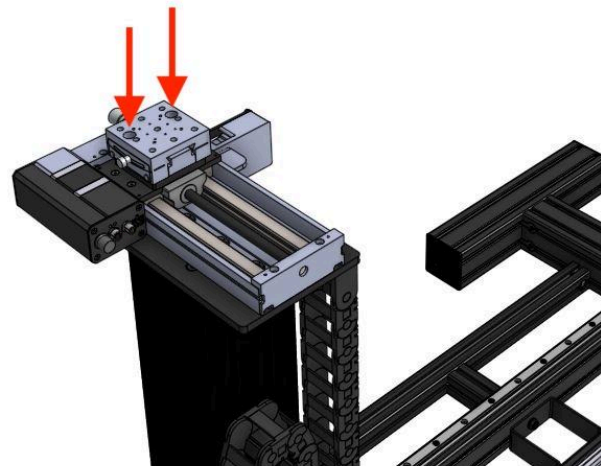
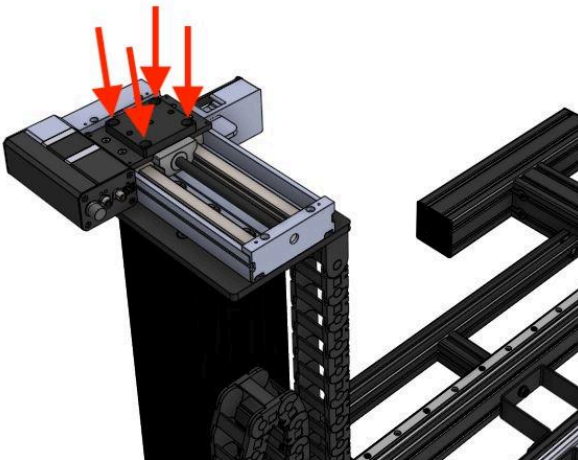

14. If using the Motorized Gimbal with the motorized x-axis Modular Test Stand:
 - a. Mount the adapter plate (Part GC) to the x-axis stage using four M6 x 12mm screws. Tighten with a 5mm hex key **Ensure to match the orientation shown above.**

15. Mount the Goniometer (Part GB) to the Adapter Plate (Part GC) using two M6 x 12mm screws, as shown above. Tighten with a 5mm hex key. **Ensure to match the orientation shown above.**

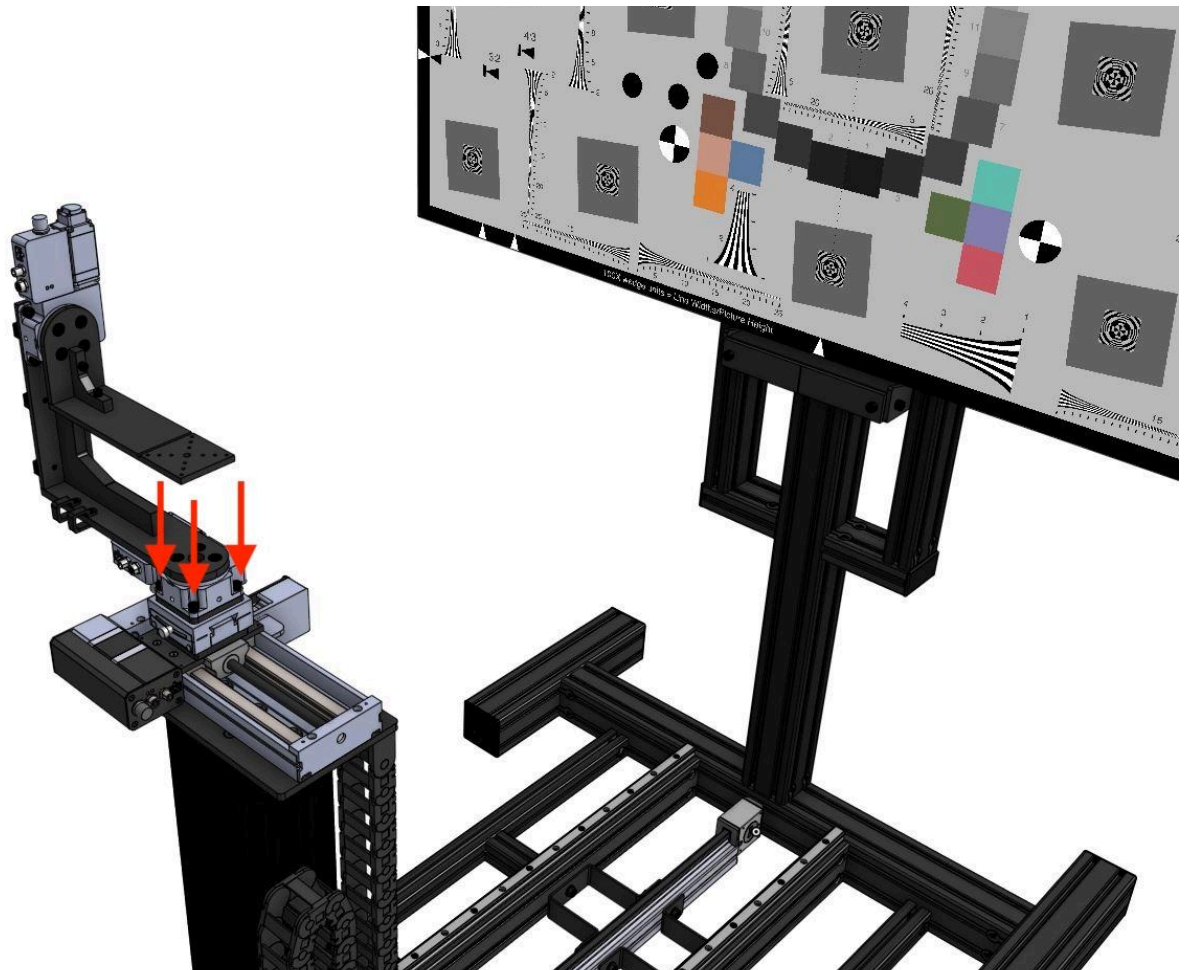

16. Mount the Motorized Gimbal (Part GA) to the Goniometer (Part GB) using three M6 x 16mm screws (Part GE), as shown in the image above. Tighten with a 5mm hex key. **Ensure to match the orientation shown above.**

Assembly Instructions - Converting to the Stray Light Configuration

17. Unmount the Motorized Gimbal by removing three M6 x 16mm screws from Step 16
18. Unmount the Goniometer by removing the two M6 x 12mm screws from Step 15
19. Unmount the Adapter Plate (Part GC) by removing the four M6 x 12mm screws from Step 14 (or Step 13)
20. Continue to the Stray Light Configuration Instructions (Page 5)

NOTE: These instructions are also applicable for the Adjustable Motorized Gimbal